

438

Window for Perfusion Chamber

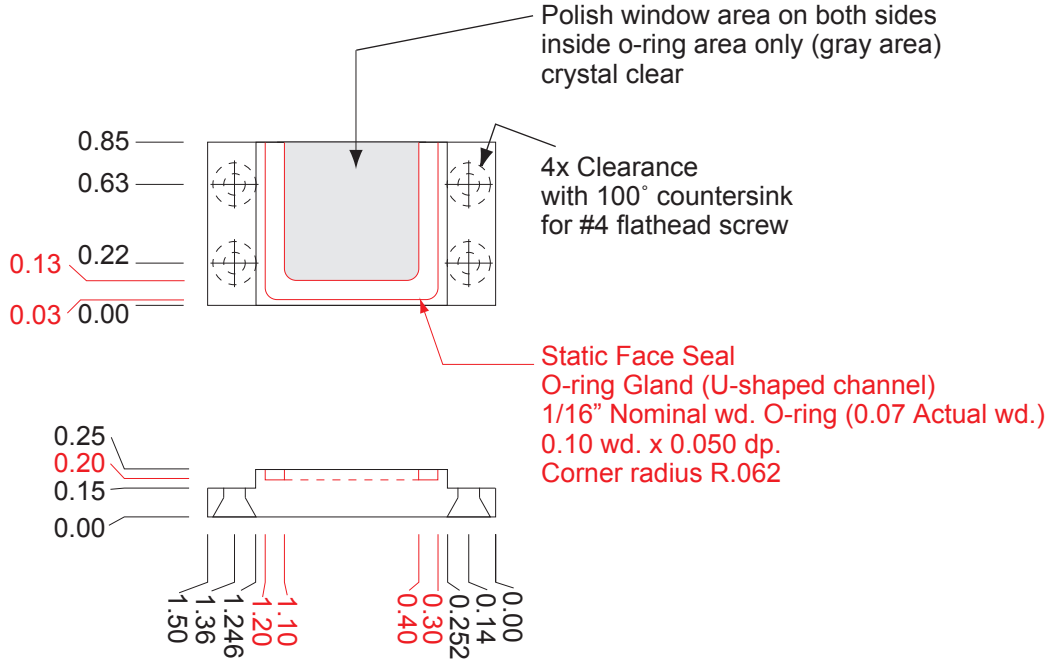

Part: Bilayer Perfusion Chamber Window
Material: Polysulfone
Scale: 1" = 1"