

416

Front Door Hinge Faraday Cage, Rev. 1

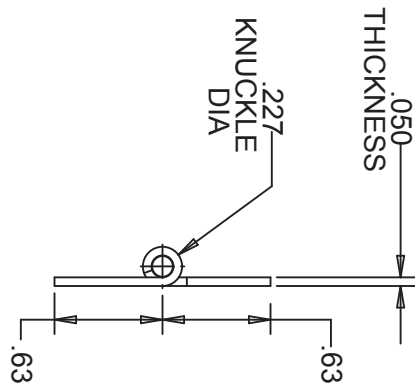
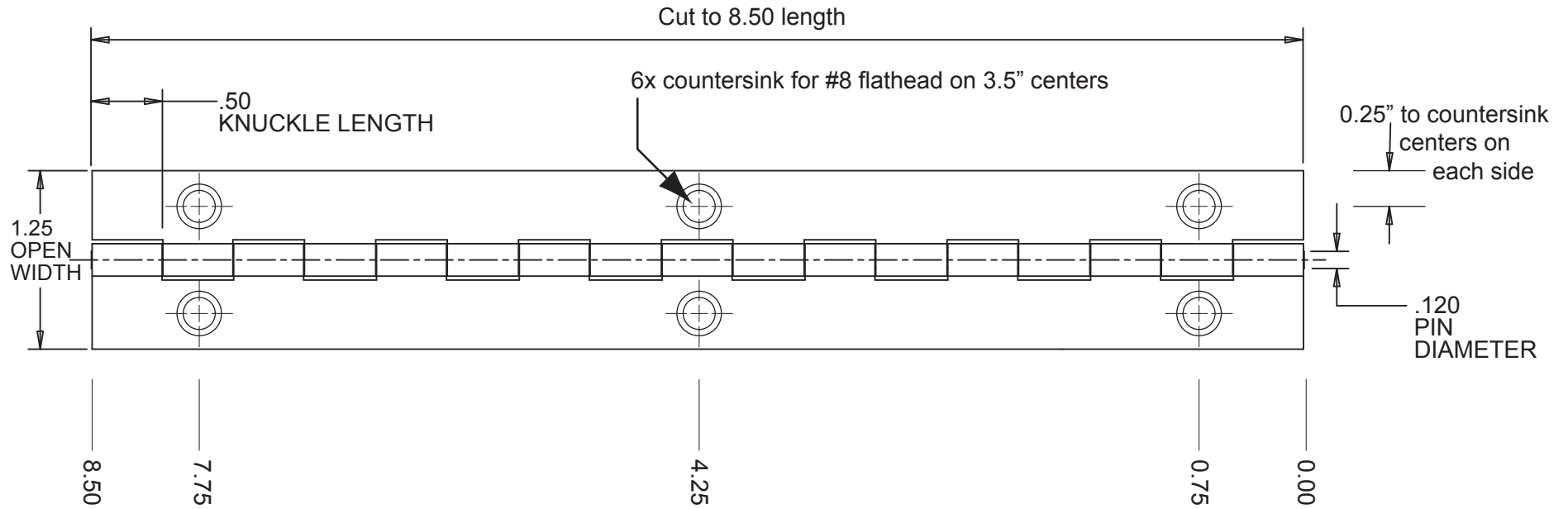

Type 304 SS
Piano Hinge Without Holes .050" Thick,
1-1/4" W Open, 1/8" Pin Dia, 3'Length
McMaster P/N 1582A14

Scale: 0.9"=1"

417



McMaster P/N 91833A132
18-8 Stainless Steel Round Knurled Thumb
Nut 10-32 Screw Size, 7/16" O'all Height, 1"
Head Dia

418

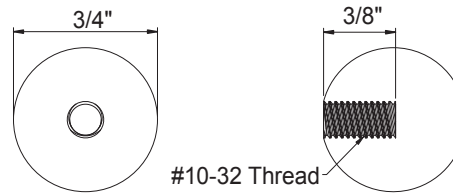

Aluminum Ball Knob 10-32 Thread,
3/4" Diameter
McMaster P/N 6940K13

419

Rear plate Faraday Cage, Rev. 1

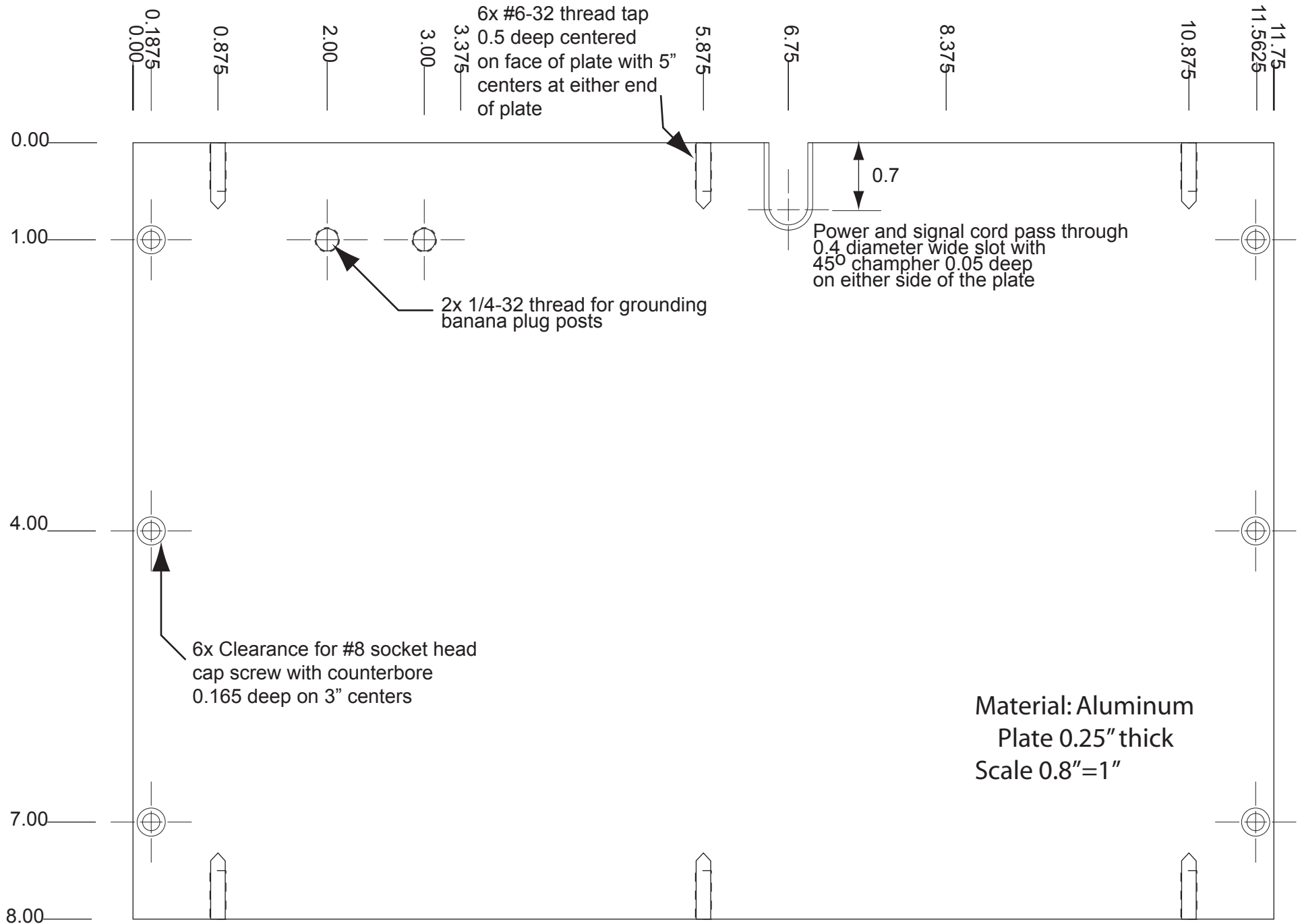

420

Top Lid Hinge Faraday Cage, Rev. 1

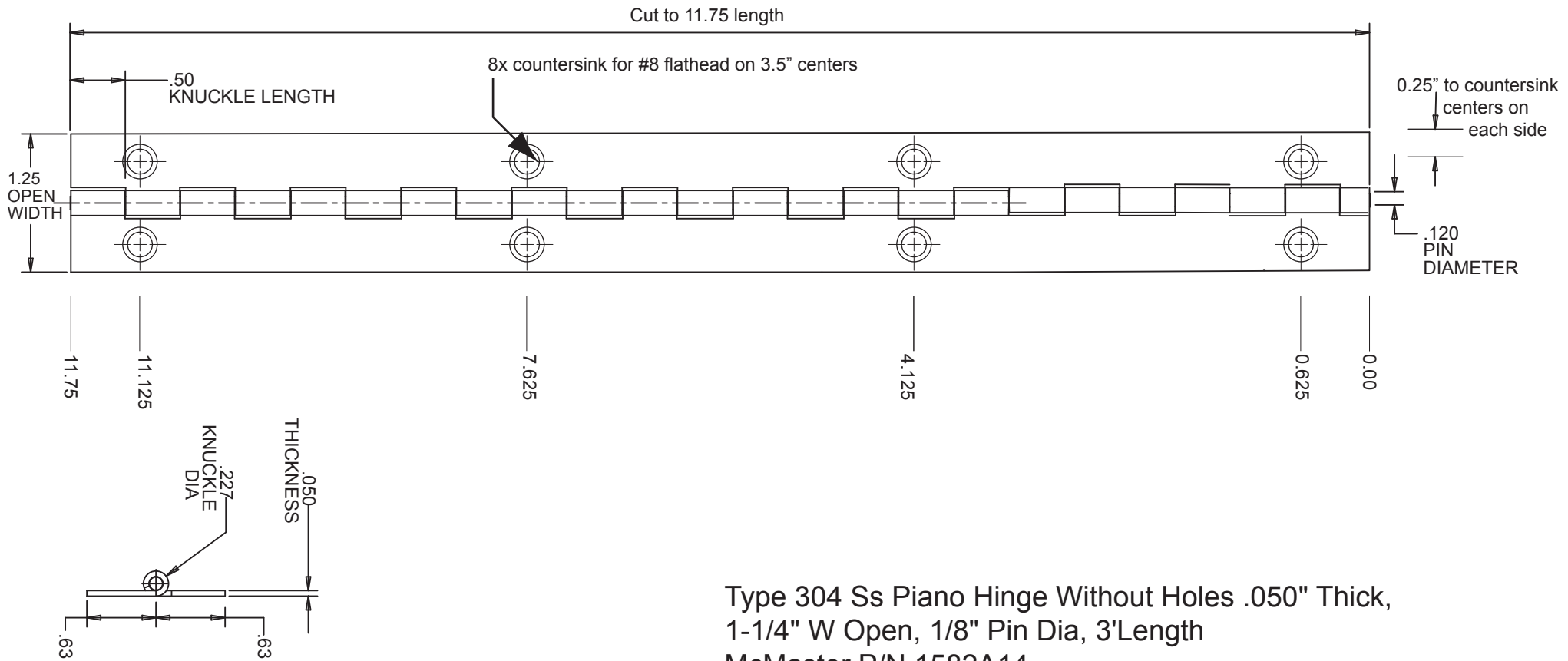

Type 304 Ss Piano Hinge Without Holes .050" Thick,
1-1/4" W Open, 1/8" Pin Dia, 3'Length
McMaster P/N 1582A14

Scale: 0.75=1"

421

Top Lid Plate Faraday Cage, Rev. 1

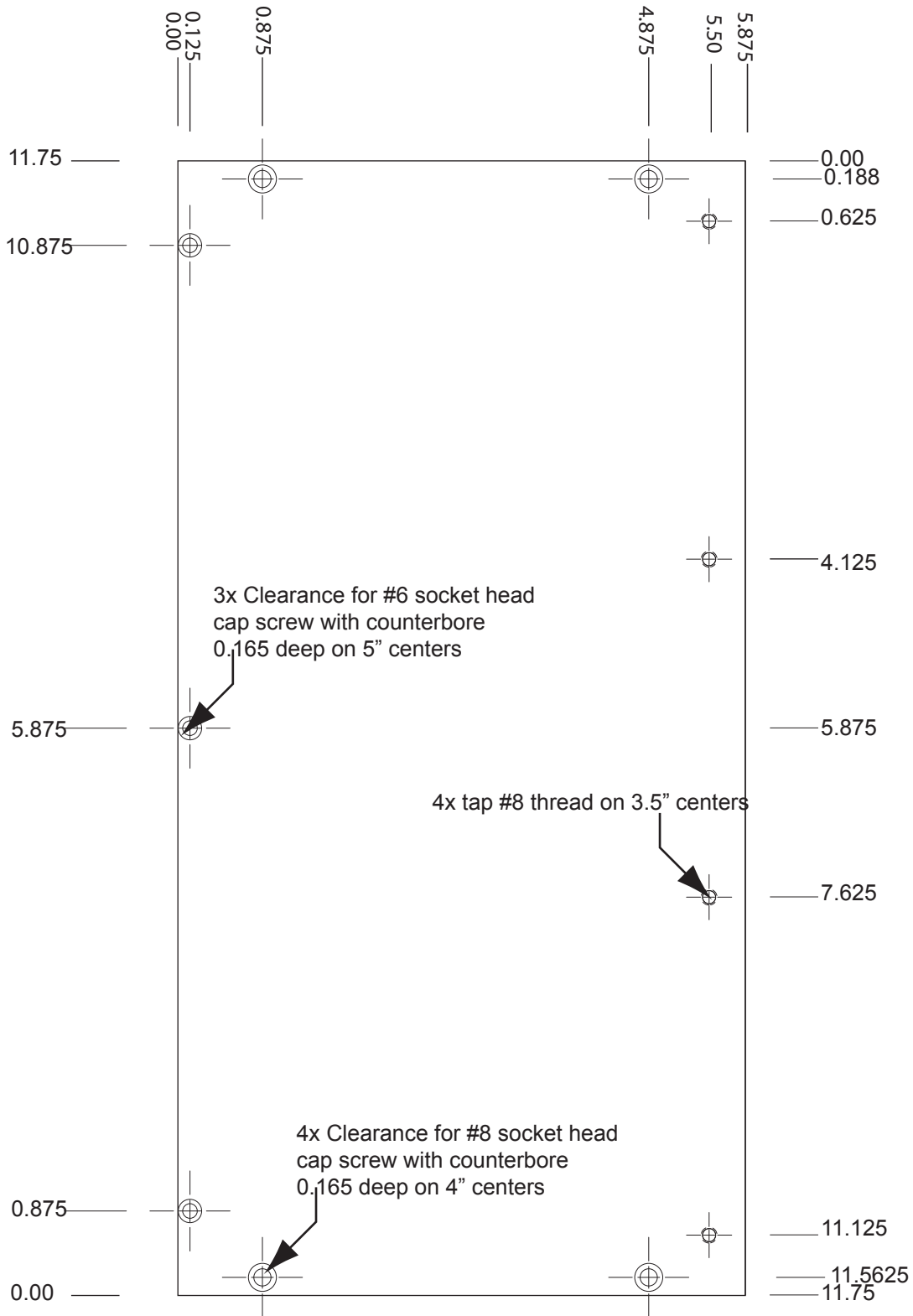

Aluminum plate 0.25 thick
Scale: 0.6=1"

Top Lid Door Faraday Cage, Rev. 1

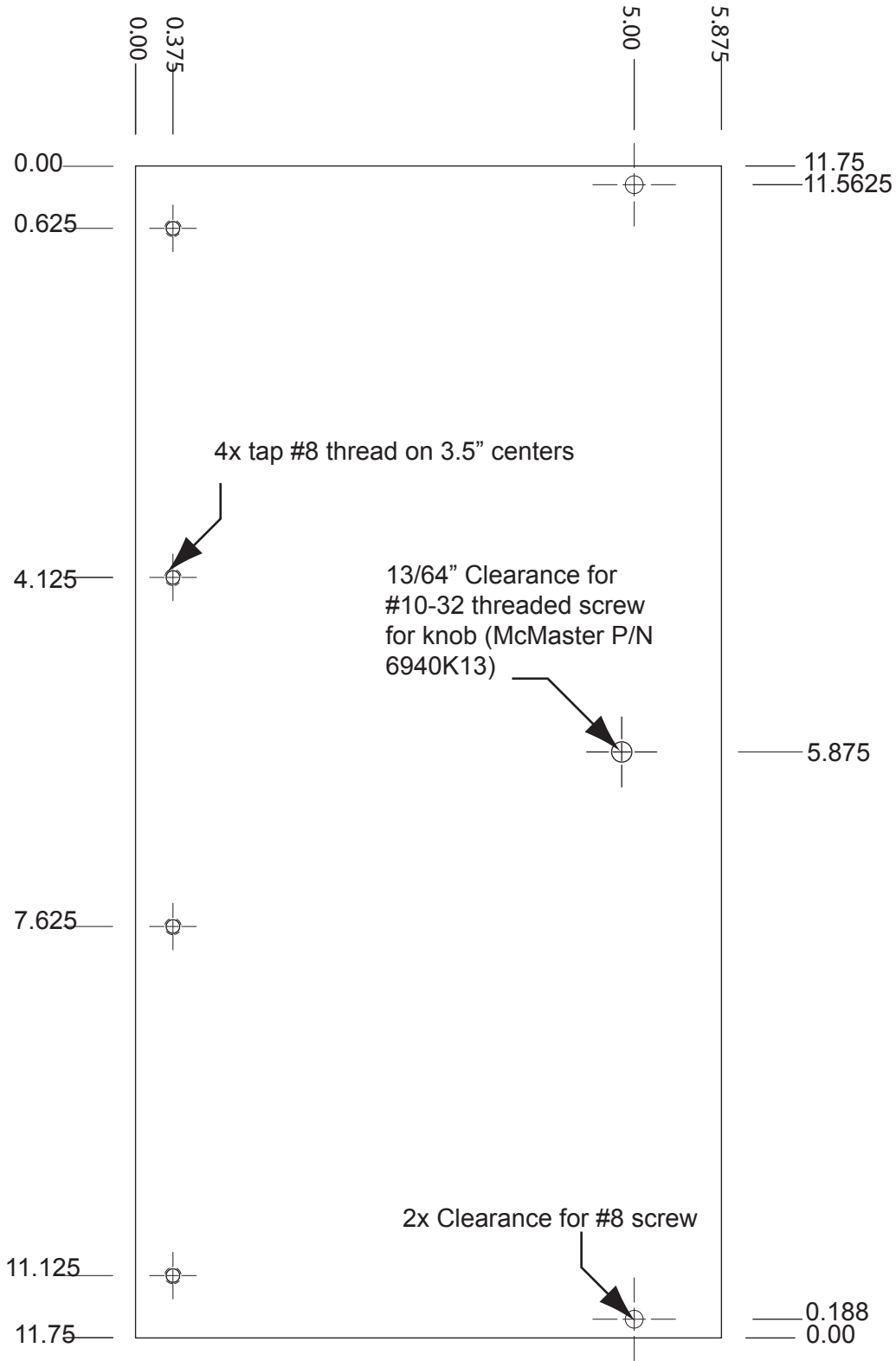

Aluminum plate 0.25 thick
Scale: 0.6=1"

423

Bottom Plate Faraday Cage, Rev. 1

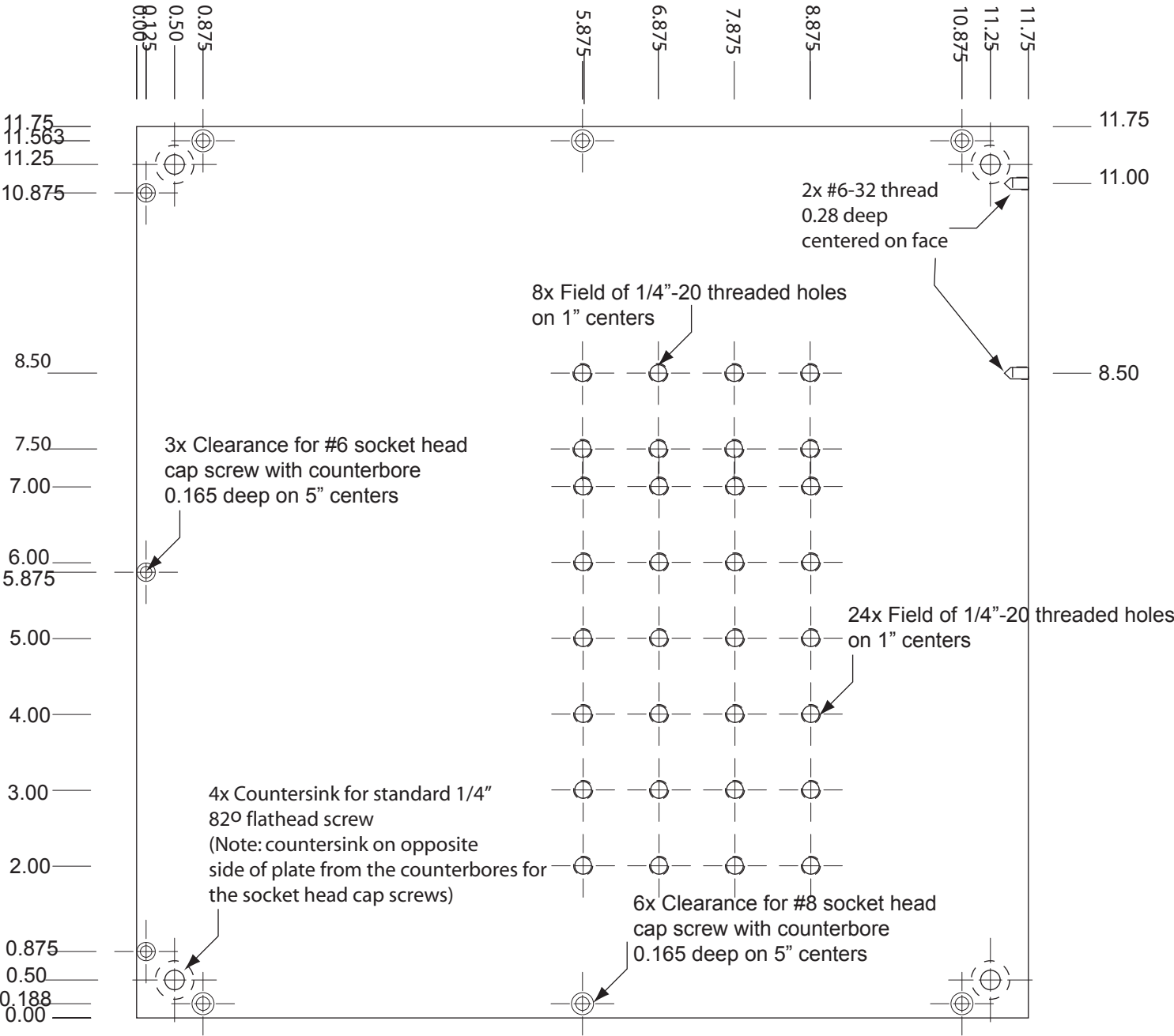

Aluminum Plate 0.25 Thick
Scale: 0.5=1"

424

Left Plate Faraday Cage, Rev. 1

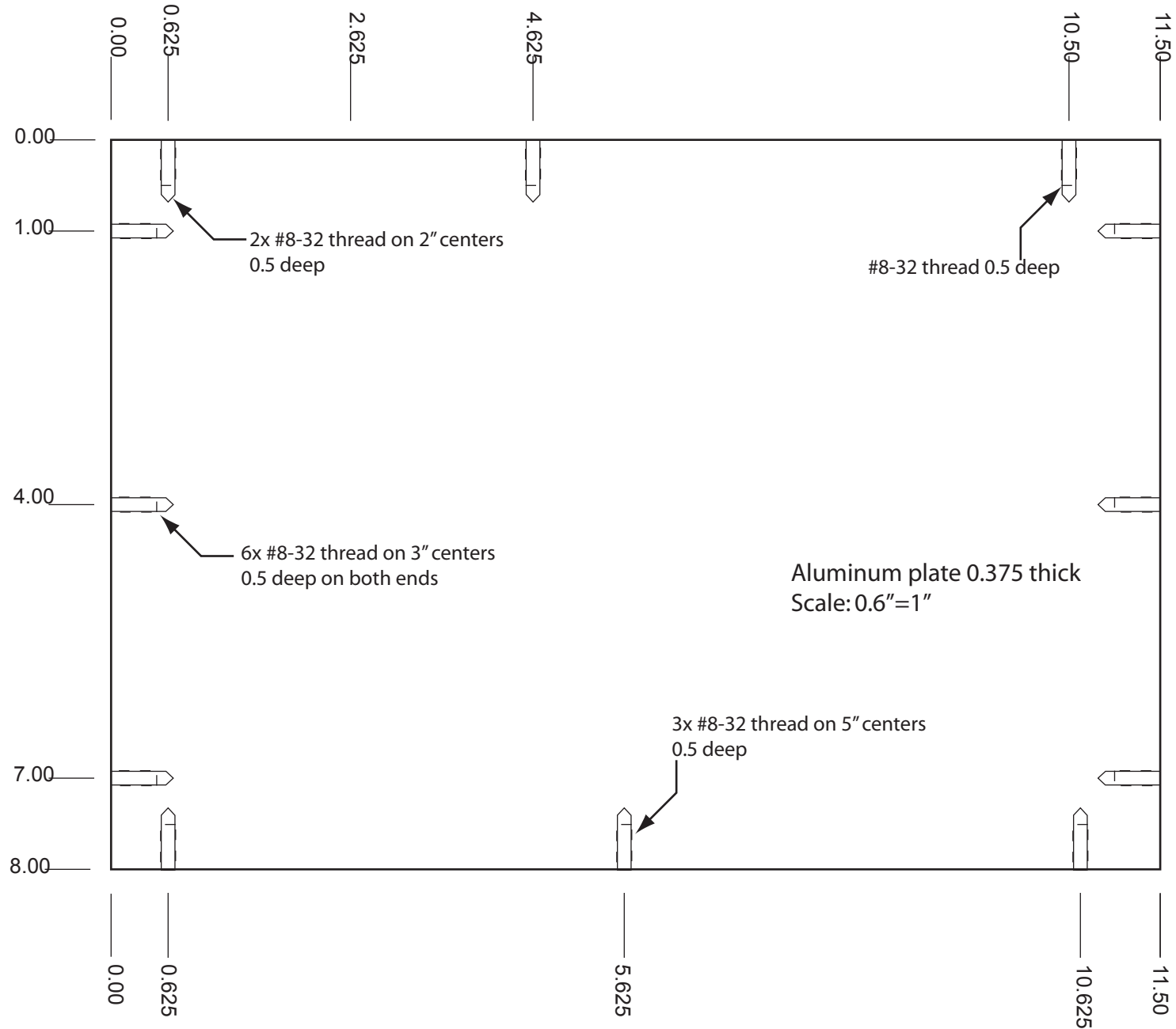

425

Right Plate Faraday Cage, Rev. 1

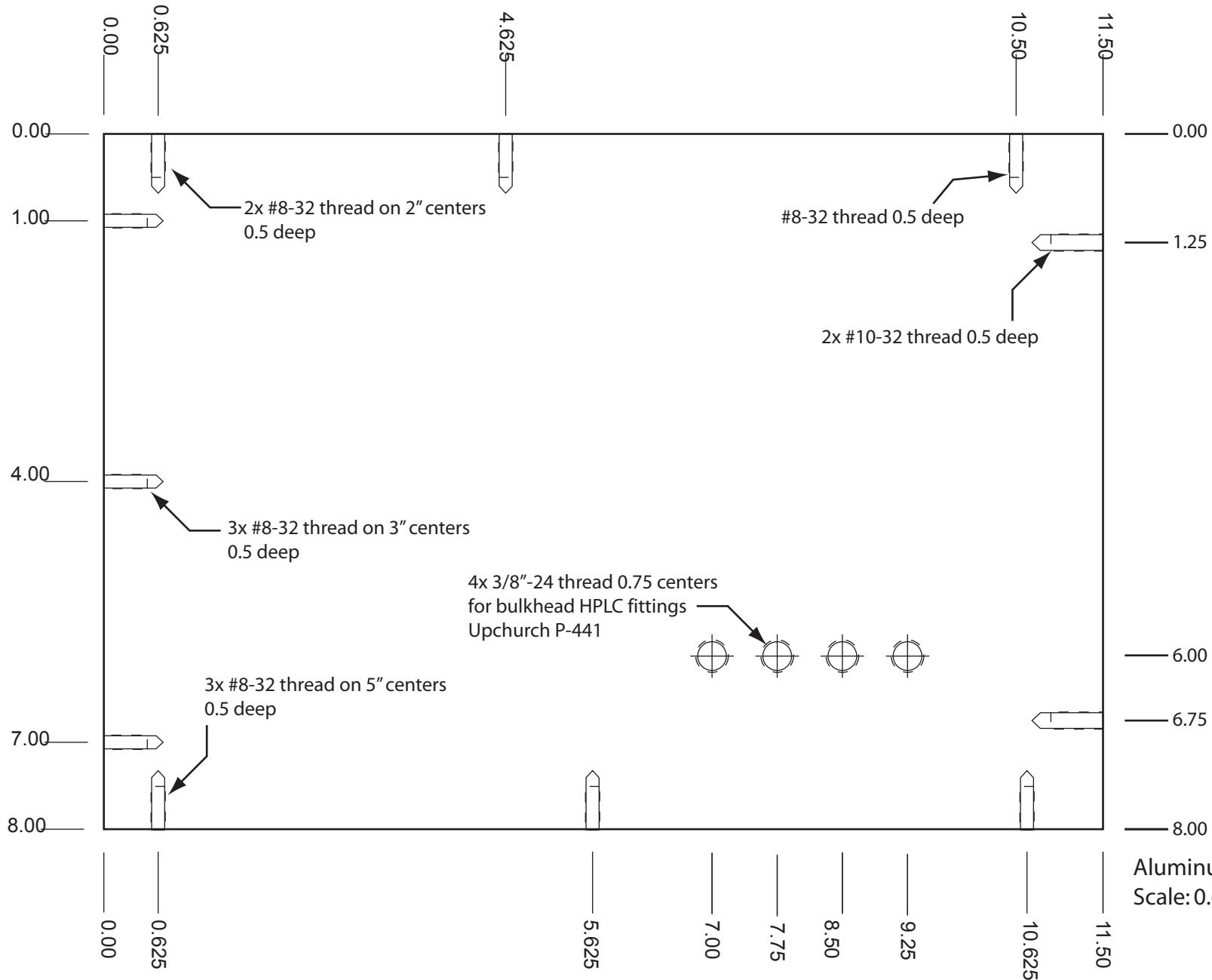

Aluminum plate 0.375 thick
Scale: 0.6"=1"

426 Leg Faraday Cage

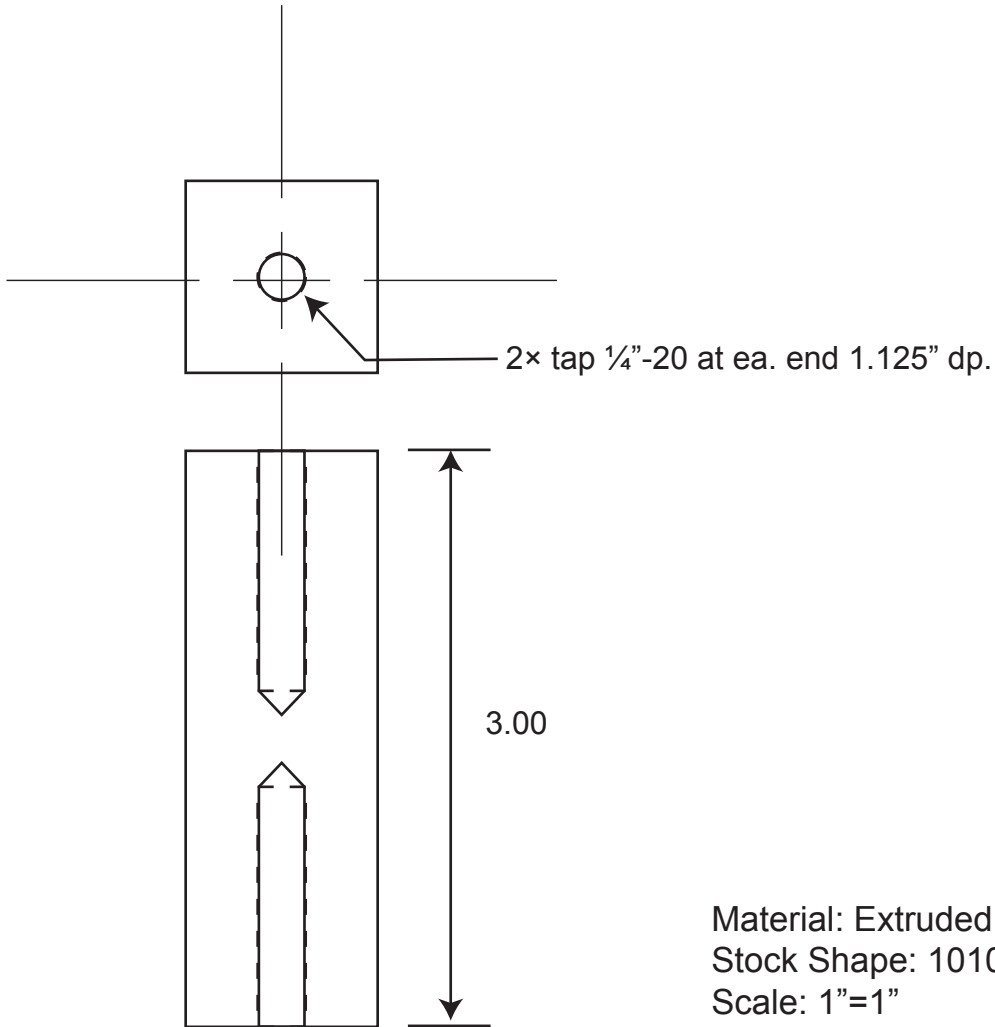

427 Rubber Foot Faraday Cage

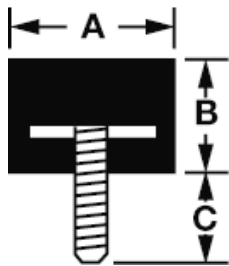

Mcmaster P/N 2572K22
Shock Absorbing Threaded Bumper 11-18 lb Max
Load, 1-1/2" Dia, 1/4"-20 Threaded Stud

428

Front Plate Faraday Cage, Rev. 2

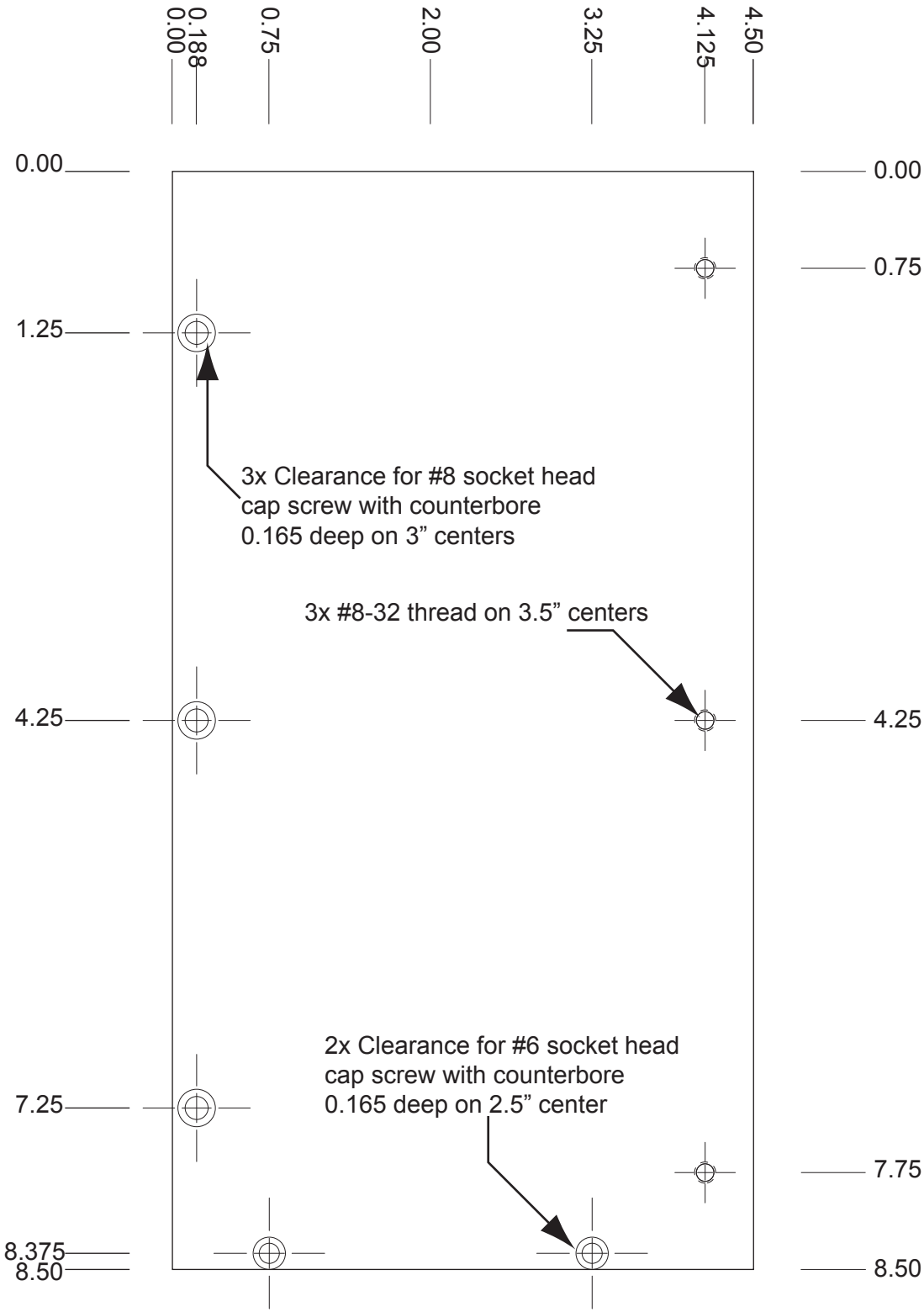

Material: Aluminum
Plate 0.25" thick
Scale 0.8"=1"

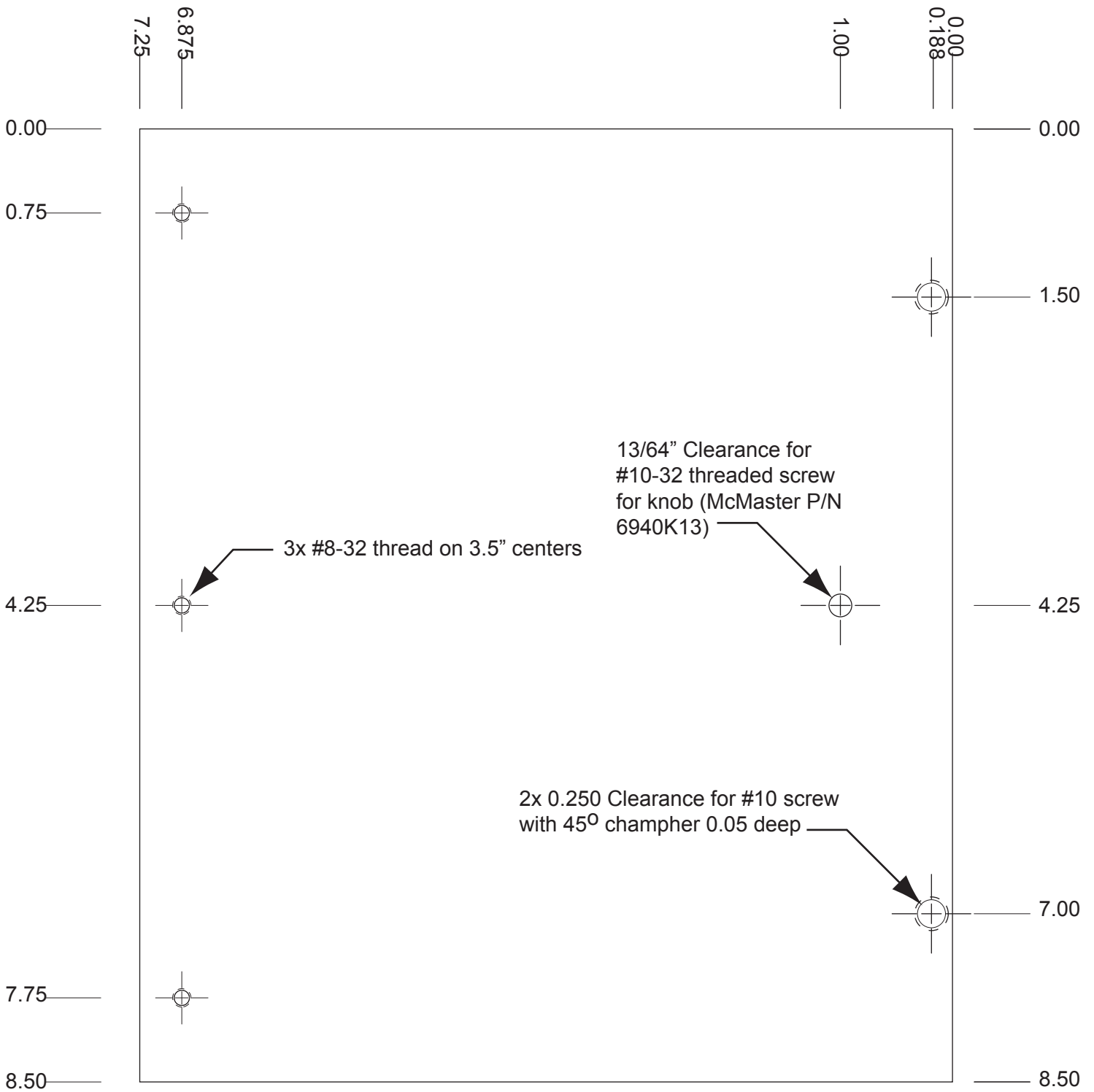

Material: Aluminum
Plate 0.25" thick
Scale 0.8"=1"